

## Climate Control System - General Information -

## Lubricant

Item	Specification
Compressor oil	SP-15

## Lubricant

Item	Specification
Compressor oil	SP-15
Total system capacity	600g +/- 25g
Compressor	4.56 FL. OZ

## System Refrigerant Specification/Capacity

Item	Specification
Refrigerant type	R134A
Total system capacity	600g +/- 25g

## General Specification

Item	Description
Compressor:	
Make	Sandan
Type	SD7H15

# Climate Control System - General Information - Climate Control System

Description and Operation

## COMPONENT LOCATION

NOTE: left-hand drive (LHD) vehicle shown, right-hand drive (RHD) similar.

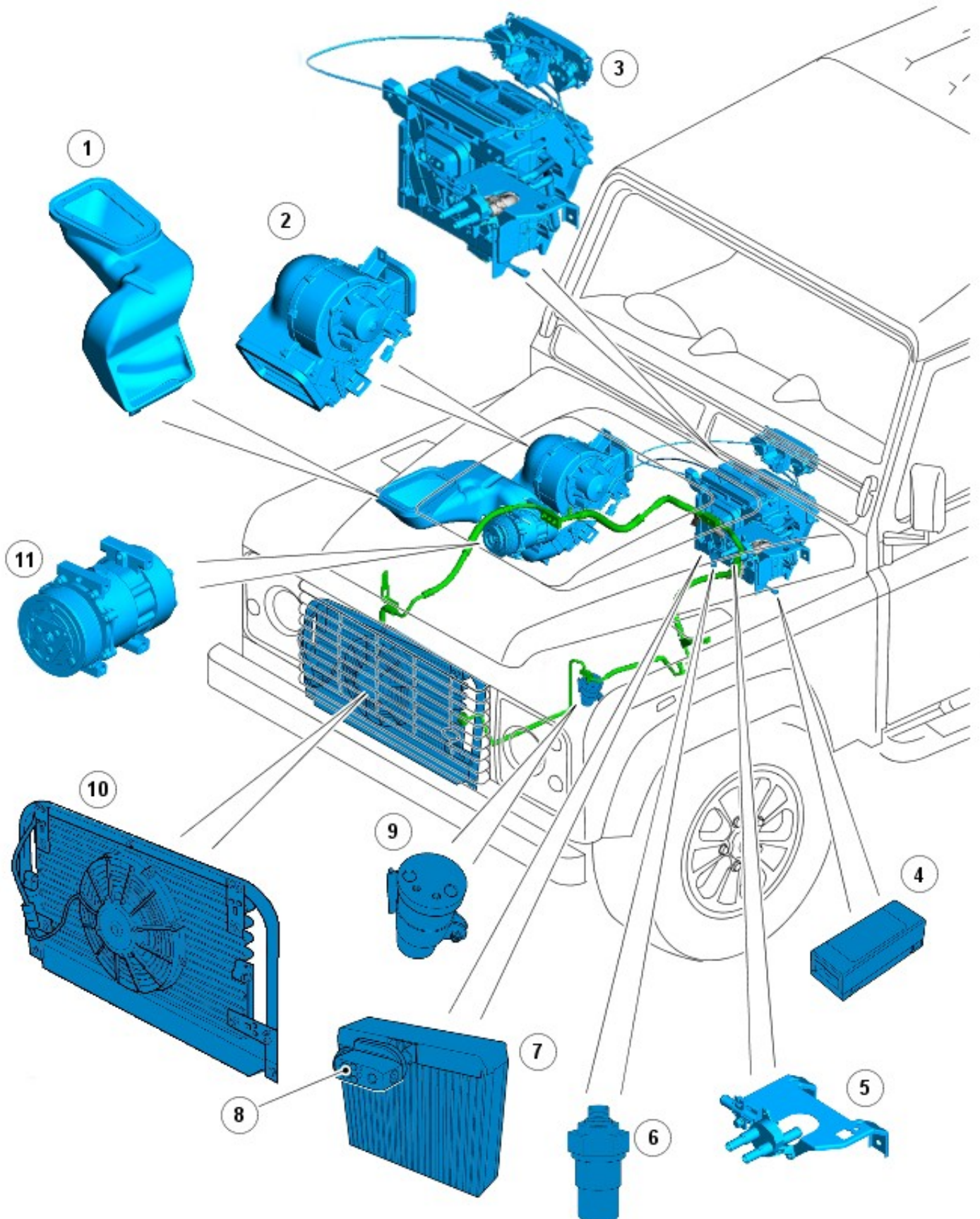

cardiagn.com

Item	Part Number	Description
1	-	Air inlet duct
2	-	Air intake and blower assembly
3	-	Heater assembly and controls
4	-	air conditioning (A/C) thermostatic switch
5	-	Water valve and bracket assembly
6	-	A/C refrigerant pressure switch
7	-	A/C evaporator
8	-	A/C thermostatic expansion valve
9	-	A/C receiver drier
10	-	A/C condenser assembly
11	-	A/C compressor

## OVERVIEW

The climate control system features heating, and where fitted, A/C operations. Heating selections are made using the left-hand (LH) rotary control mounted on the center console. The rotary control is connected via a Bowden cable to a water valve in the engine cooling system. The water valve allows a varying amount of engine coolant to flow into the heater matrix. The amount of coolant entering the heater matrix determines the heat transferred to the inlet air and thus the amount of heat transferred into the cabin.

Blower motor speed is controlled using a 4 position sliding switch. The switch allows 3 blower motor speeds to be selected by controlling the ground path for the blower motor in conjunction with a resistor pack. The blower motor and resistor pack are both located in the engine compartment.

Air distribution into the cabin is selected using the right-hand (RH) rotary control mounted on the center console. Air intake into the cabin is controlled by a 2 position sliding switch which is also located on the center console. For additional information, refer to: Air Distribution and Filtering (412-01, Description and Operation).

The A/C system is switched on and off using the switch located in the center console. The system will only operate when the engine is running. If A/C is requested when blower motor speed is set to 0, blower motor speed 1 will be engaged automatically.

The engine control module (ECM) monitors the engine running status and suspends A/C operation if necessary by inhibiting the compressor clutch relay.

The heated seats, heated windshield, and heated rear window systems are not part of the climate control system. For additional information, refer to:

- Seats (501-10, Description and Operation),
- Glass, Frames and Mechanisms (501-11, Description and Operation).

## AIR INLET DUCT

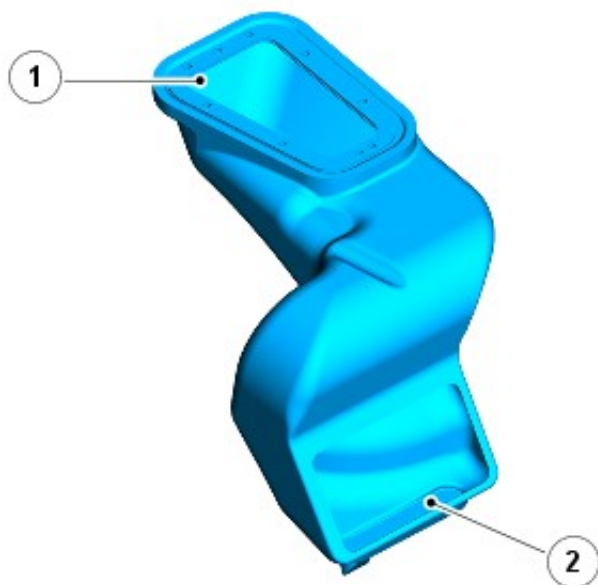

E83738

Item	Part Number	Description
1	-	Air inlet
2	-	Air outlet to blower assembly

The air inlet duct is mounted in the passenger side front fender. Air is drawn into the air inlet duct through a vent on the upper surface of the fender. The air inlet duct directs air into the air intake and blower assembly. The air intake and blower assembly features a Bowden cable operated flap which allows the user to switch between fresh or recirculated air entering the cabin.

## AIR INTAKE AND BLOWER ASSEMBLY

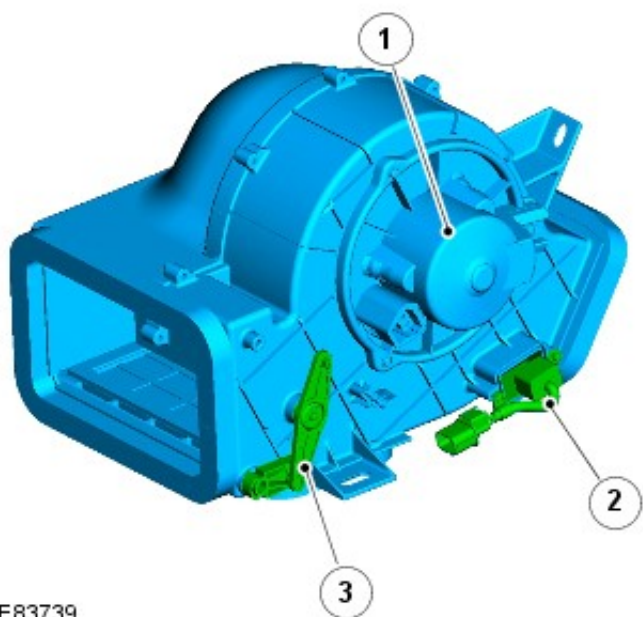

E83739

Item	Part Number	Description
1	-	Blower motor
2	-	Resistor pack
3	-	Fresh/recirculated air flap

The air intake and blower assembly is mounted on the passenger side of the engine compartment. The blower comprises a centrifugal fan powered by an electric motor. The motor is able to operate at 3 speeds, which are controlled by a resistor pack mounted on the inboard side of the blower motor casing. Air leaving the air intake and blower assembly is directed into the rear of the heater assembly.

## HEATER ASSEMBLY

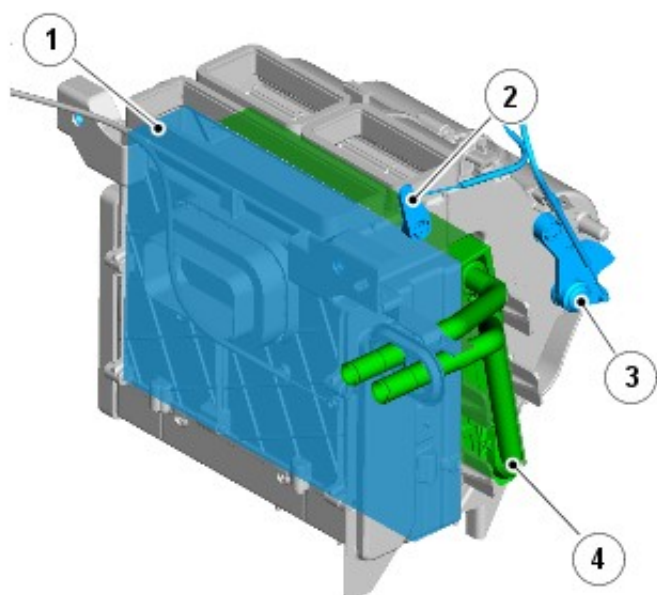

E83740

Item	Part Number	Description
1	-	Diffuser plate
2	-	Windshield/face level air distribution door cam
3	-	Footwell air distribution door cam
4	-	Heater matrix

The heater assembly is mounted behind the instrument panel on the vehicle center line. The heater assembly contains an aluminum heater matrix and a diffuser plate to deliver the required air temperature into the cabin. If the vehicle is fitted with A/C, the A/C evaporator replaces the diffuser plate in the heater assembly.

Air distribution into the cabin is controlled by 2 air distribution doors. The doors are operated via a Bowden cable from the RH rotary control on the center console.

## WATER VALVE

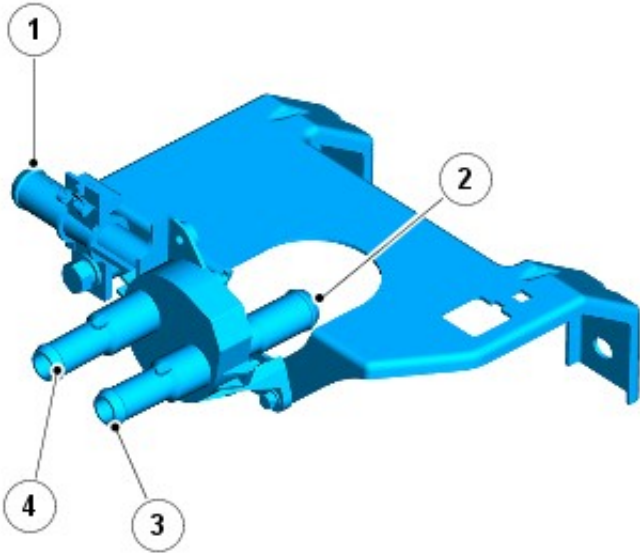

E83741

Item	Part Number	Description
1	-	Return from heater matrix
2	-	Supply to heater matrix
3	-	Supply from engine cooling system
4	-	Return to engine cooling system

The water valve is mounted at the rear of the engine compartment. A Bowden cable acts on a lever on the rear face of the water valve to vary the flow of hot engine coolant into the heater matrix. When the water valve is fully closed, no engine coolant is allowed to flow into the heater matrix. In this instance, engine coolant will flow into the water valve through inlet (3) and immediately out through the return (4).

## AIR CONDITIONING COMPRESSOR

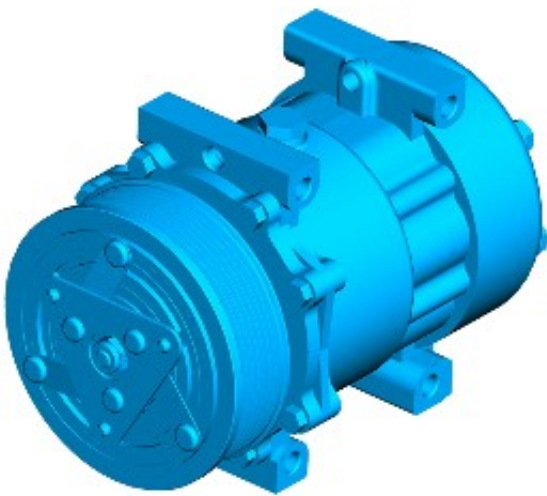

E83742

The A/C compressor circulates refrigerant around the system by compressing low pressure, low temperature vapor from the evaporator and discharging the resultant high pressure, high temperature vapor to the condenser.

The A/C compressor is a constant displacement unit which is driven by the engine accessory drive belt. To protect the

system from excessive pressure, a pressure relief valve is installed in the outlet side of the A/C compressor. The pressure relief valve vents excess pressure into the engine compartment.

Compressor clutch engagement is controlled by the ECM. The ECM receives system pressure inputs from the refrigerant pressure switch and system temperature inputs from the thermostatic switch. The ECM will de-energize the A/C compressor clutch relay on receipt of a pressure reading above or below the system limits, or a temperature reading that may cause the evaporator to freeze. For more information, refer to the 'Air Conditioning Refrigerant Pressure Switch' and 'Thermostatic Switch' sections below.

## AIR CONDITIONING CONDENSER

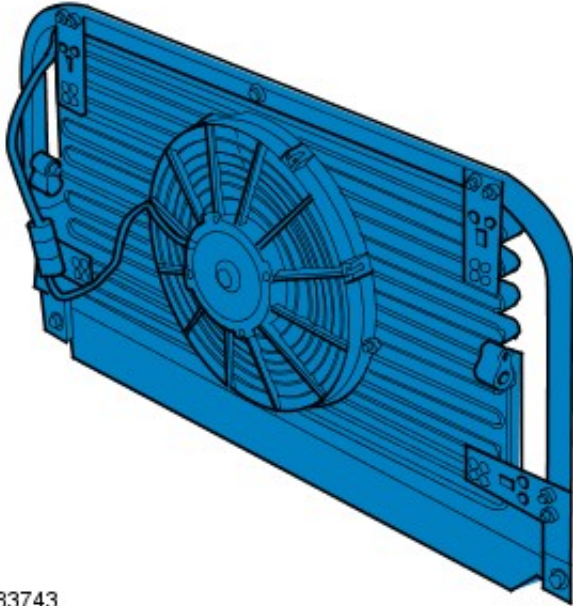

E83743

The condenser transfers heat from the refrigerant to the surrounding air to convert the high pressure vapor from the compressor into a liquid. The condenser is installed immediately in front of the radiator and is held in place by 3 brackets; 1 at the top, 2 at the bottom.

The RH end of the condenser provides a connection to the high pressure line from the A/C compressor. The LH end of the condenser provides a connection to the low pressure line to the receiver drier.

## AIR CONDITIONING RECEIVER DRIER

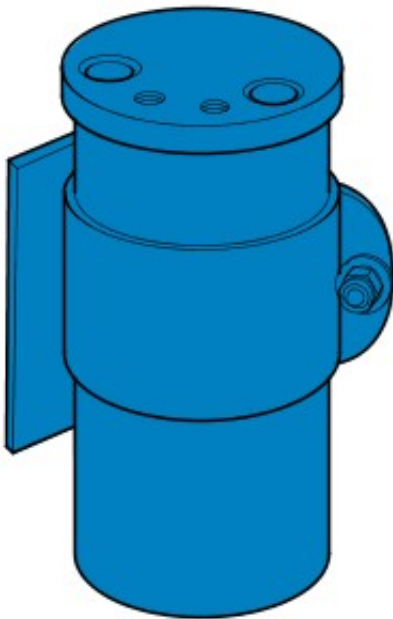

E83744

The receiver drier is mounted in the LH front corner of the engine compartment and removes solid impurities and moisture from the refrigerant. It also provides a reservoir for liquid refrigerant to accommodate changes of heat load at the evaporator.

Refrigerant entering the receiver drier passes through a filter and a desiccant pack, then collects in the base of the unit before flowing through the outlet pipe to the evaporator.

## AIR CONDITIONING EVAPORATOR

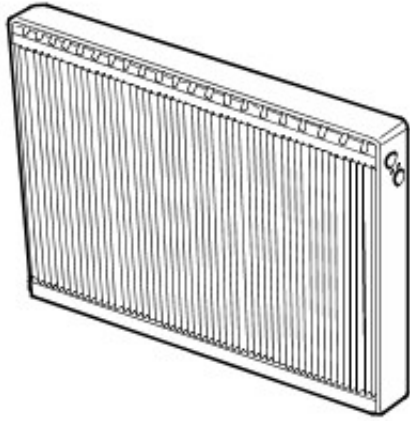

E46923

The evaporator is installed in the heater assembly. Liquid refrigerant enters the evaporator and expands, absorbing large quantities of heat as it changes state to a gas.

Most of the moisture in the air passing through the evaporator condenses into water, which drains out of the vehicle by passing through a drain tube to the underside of the vehicle.

## AIR CONDITIONING THERMOSTATIC EXPANSION VALVE

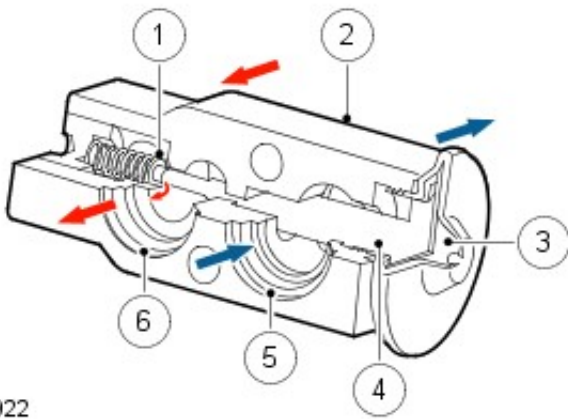

E46922

Item	Part Number	Description
1	-	Metering valve
2	-	Housing
3	-	Diaphragm
4	-	Temperature sensor
5	-	Outlet passage from evaporator
6	-	Inlet passage to evaporator

The thermostatic expansion valve meters the flow of refrigerant into the evaporator, to match the refrigerant flow with the heat load of the air passing through the evaporator.

The thermostatic expansion valve is a block type valve located behind the heater assembly, and attached to the inlet and outlet ports of the evaporator. The thermostatic expansion valve consists of an aluminum housing containing inlet and outlet passages. A ball and spring metering valve is installed in the inlet passage and a temperature sensor is installed in the outlet passage. The temperature sensor consists of a temperature sensitive tube connected to a diaphragm. The bottom end of the temperature sensitive tube acts on the ball of the metering valve. Pressure on top of the diaphragm is controlled by the evaporator outlet temperature conducted through the temperature sensitive tube. The bottom of the diaphragm senses evaporator outlet pressure.

Liquid refrigerant flows through the metering valve into the evaporator. The restriction across the metering valve reduces the pressure and temperature of the refrigerant. The restriction also changes the liquid stream of refrigerant into a fine spray, to improve the evaporation process. As the refrigerant passes through the evaporator, it absorbs heat from the air flowing through the evaporator. The increase in temperature causes the refrigerant to vaporize and increase in pressure.

The temperature and pressure of the refrigerant leaving the evaporator acts on the diaphragm and temperature sensitive tube, which regulate the metering valve opening and so control the volume of refrigerant flowing through the evaporator. The warmer the air flowing through the evaporator, the more heat available to evaporate refrigerant and thus the greater volume of refrigerant allowed through the metering valve.

## AIR CONDITIONING REFRIGERANT PRESSURE SWITCH

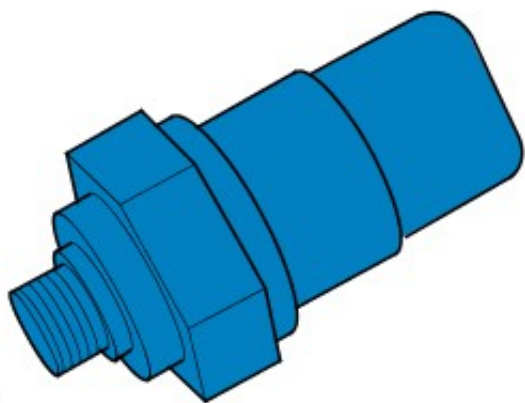

E83745

The refrigerant pressure switch is mounted monitors the high pressure side of the A/C system. The switch monitors 3 pressure ranges; high, medium and low. The pressure of refrigerant inside the system is provided to the ECM, which controls operation of the A/C compressor accordingly.

The pressure ranges monitored by the switch are as follows:

Pressure Range	Upper Limit (bar)	Lower Limit (bar)
High	32	6
Medium	15.5	12.5
Low	2.3	2

If the pressure in the system falls below 2 bar, or rises above 32 bar, the ECM will suspend A/C compressor operation by de-energizing the main relay, which subsequently de-energizes the A/C compressor clutch relay.

#### AIR CONDITIONING THERMOSTATIC SWITCH

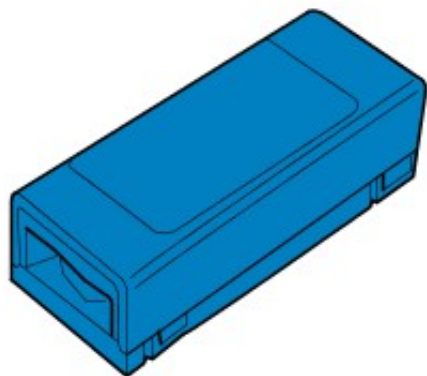

E83746

The thermostatic switch is mounted on the underside of the heater assembly and measures the temperature of the air coming off the A/C evaporator. This temperature value is fed back to the ECM which controls operation of the A/C compressor accordingly.

The ECM will suspend A/C compressor operation if the temperature of the air coming off the evaporator drops to 1°C (34 °F). This prevents the evaporator from freezing. The ECM will re-instate A/C compressor operation when the temperature of the air coming off the evaporator rises to 3.5°C (38°F).

#### CONTROL DIAGRAM

NOTE: A = Hardwired



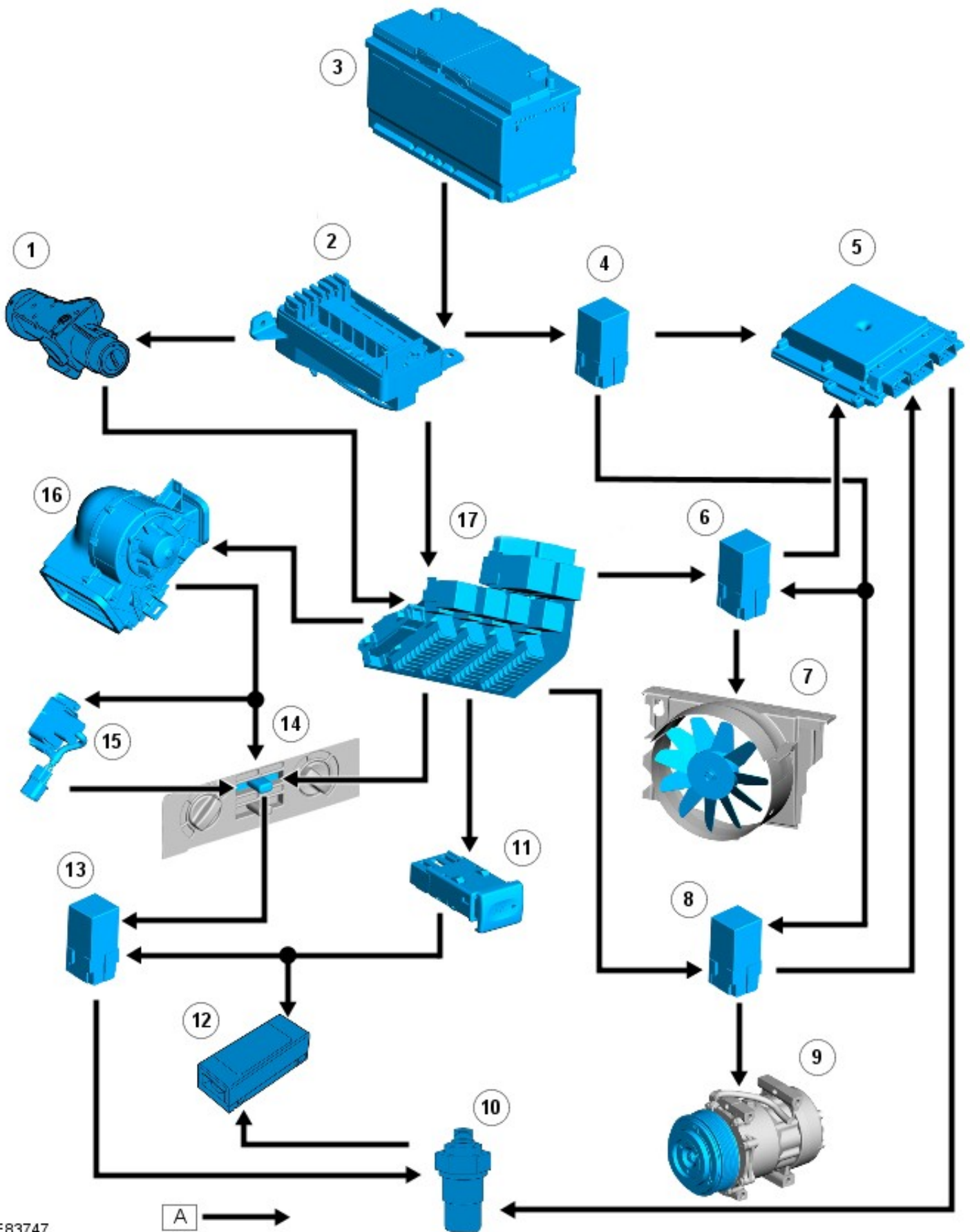

E83747

Item	Part Number	Description
1	-	Ignition switch
2	-	battery junction box (BJB)
3	-	Battery
4	-	Main relay
5	-	ECM
6	-	Cooling fan relay

7	-	Cooling fan
8	-	A/C compressor clutch relay
9	-	A/C compressor clutch
10	-	A/C refrigerant pressure switch
11	-	A/C switch
12	-	A/C thermostatic switch
13	-	Blower motor relay
14	-	Blower motor switch
15	-	Blower motor resistor pack
16	-	Blower motor
17	-	central junction box (CJB)

## PRINCIPLES OF OPERATION

### Heating

Heating control is achieved by varying the amount of engine coolant fed into the heater matrix. Coolant is bled from the engine cooling system and fed into the heater matrix through the water valve. The water valve is operated via a Bowden cable from the rotary heater control and varies the amount of engine coolant entering the heater matrix in response to heating demand.

If partial heating is requested, a proportion of engine coolant is returned back to the engine cooling system. If no heating is requested, the water valve returns all engine coolant back to the engine cooling system, by-passing the heater matrix.

Heat is transferred to the inlet air as it passes through the heater matrix. The heated air is then delivered into the cabin through a series of ducts, vents, and registers.

For additional information, refer to: Air Distribution and Filtering (412-01, Description and Operation).

### Air Conditioning

The A/C system transfers heat from the cabin to the outside atmosphere to provide dehumidified cool air. The A/C system is a sealed closed loop system, filled with a charge weight of R134a refrigerant as the heat transfer medium. Oil is added to the refrigerant to lubricate the internal components of the A/C compressor.

Hot, high pressure gas from the compressor flows into the condenser, which allows heat to dissipate causing the gas to condense into a liquid form. The flow of liquid refrigerant into the evaporator is controlled by the thermostatic expansion valve. When in the evaporator the liquid refrigerant expands and absorbs heat from its surroundings, cooling the fins and plates of the A/C evaporator. As inlet air passes across the A/C evaporator surface it is cooled before entering the cabin through a series of ducts, vents, and registers.

For additional information, refer to: Air Distribution and Filtering (412-01, Description and Operation).

# Climate Control System - General Information - Climate Control System

## Diagnosis and Testing

### GENERAL PRECAUTIONS

The refrigerant used in the air conditioning system is HFC (Hydrofluorocarbon) R134a.

#### WARNINGS:



R134a is a hazardous liquid and when handled incorrectly can cause serious injury. Suitable protective clothing must be worn when carrying out servicing operations on the air conditioning system.



R134a is odourless and colourless. Do not handle or discharge in an enclosed area, or in any area where the vapour or liquid can come in contact with naked flame or hot metal. R134a is not flammable, but can form a highly toxic gas.



Do not smoke or weld in areas where R134a is in use. Inhalation of concentrations of the vapour can cause dizziness, disorientation, uncoordination, narcosis, nausea or vomiting.



Do not allow fluids other than R134a or compressor lubricant to enter the air conditioning system. Spontaneous combustion may occur.



R134a splashed on any part of the body will cause immediate freezing of that area. Also refrigerant cylinders and replenishment trolleys when discharging will freeze skin to them if contact is made.



The refrigerant used in an air conditioning system must be reclaimed in accordance with the recommendations given with a Refrigerant Recovery Recycling Recharging Station.

NOTE: Suitable protective clothing comprises: Wrap around safety glasses or helmet, heatproof gloves, rubber apron or waterproof overalls and rubber boots.

Routine servicing, apart from visual checks, is not necessary. The visual inspections are as follows:

#### Condenser

With a water hose or air line, clean the fins of the condenser to remove flies, leaves, etc. Check the pipe connections for signs of oil leakage.

#### Compressor

Check pipe connections for signs of oil leakage. Check flexible hoses for swelling. Examine the compressor belt for tightness and condition.

#### Sight glass

Examine the sight glass for bubbles with the system operating. Check connections for leakage.

#### Evaporator

Examine the refrigeration connections at the unit.

### REMEDIAL ACTIONS

#### WARNINGS:



Do not allow a refrigerant container to be heated by a direct flame or to be placed near any heating appliance. A refrigerant container must not be heated above 50° C.



Do not leave a container of refrigerant without its cap fitted. Do not transport a container of refrigerant that is unrestrained, especially in the boot of a car.

NOTE: Due to its low evaporating temperature of -30° C, R134a should be handled with care.

- If liquid R134a strikes the eye, do not rub it. Gently run large quantities of eyewash over the eye to raise the temperature. If eyewash is not available cool, clean water may be used. Cover eye with clean pad and seek immediate medical attention.
- If liquid R134a is splashed on the skin run large quantities of water over the area as soon as possible to raise the temperature. Carry out the same actions if skin comes into contact with discharging cylinders. Wrap affected parts in blankets or similar material and seek immediate medical attention.

- If suspected of being overcome by inhalation of R134a vapour seek fresh air. If unconscious remove to fresh air. Apply artificial respiration and/or oxygen and seek immediate medical attention.

## SERVICING PRECAUTIONS

Care must be taken when handling refrigeration system components. Units must not be lifted by their hoses, pipes or capillary lines. Hoses and lines must not be subjected to any twist or stress. Ensure that hoses are positioned in their correct run before fully tightening the couplings, and ensure that all clips and supports are used. Torque wrenches of the correct type must be used when tightening refrigerant connections to the stated value. An additional spanner must be used to hold the union to prevent twisting of the pipe.

Before connecting any hose or pipe ensure that refrigerant oil is applied to the seat of the new 'O' ring but not to the threads.

Check the oil trap for the amount of oil lost.

All protective plugs on components must be left in place until immediately prior to connection.

The receiver/drier contains desiccant which absorbs moisture. It must be positively sealed at all times.



**CAUTION:** Whenever the refrigerant system is opened, the receiver/drier must be renewed immediately before evacuating and recharging the system.

Use alcohol and a clean cloth to clean dirty connections. Ensure that all new parts fitted are marked for use with R134a.

Refrigerant oil

Use the approved refrigerant lubricating oil - Nippon Denso ND-OIL 8.



**CAUTION:** Do not use any other type of refrigerant oil.

Refrigerant oil easily absorbs water and must not be stored for long periods. Do not pour unused oil back into the container. When renewing system components, add the following quantities of refrigerant oil:

Component	Fluid quantity
Condenser	40ml
Evaporator	80ml
Pipe or hose	20ml
Receiver/drier	20ml
Total quantity of refrigerant oil in system	140ml

A new compressor is sealed and pressurised with Nitrogen gas, slowly release the sealing cap, gas pressure should be heard to release as the seal is broken.

**NOTE:** A new compressor should always have its sealing caps in place and these must not be removed until immediately prior to fitting

A new compressor is supplied with an oil fill of 140ml.

A calculated quantity of oil must be drained from a new compressor before fitting.

To calculate the quantity of oil to be drained:

- Remove sealing plugs from the OLD compressor.
- Invert compressor and gravity drain oil into measuring cylinder. Rotating the compressor clutch plate will assist complete draining.
- Note the quantity of oil drained (Yml).
- Calculate the quantity (Qml) of oil to be drained from the NEW compressor using the following formula:  $X\text{ml} - (Y\text{ml} + 20\text{ml}) = Q\text{ml}$

Rapid refrigerant discharge

When the air conditioning system is involved in accident damage and the circuit is punctured, the refrigerant is discharged rapidly. The rapid discharge of refrigerant will also result in the loss of most of the oil from the system. The compressor must be removed and all the remaining oil in the compressor drained and refilled as follows:

- Gravity drain all the oil, assist by rotating the clutch plate (not the pulley).
- Refill the compressor with 90ml of new refrigerant oil.
- Plug the inlet and outlet ports.

Servicing Equipment

The following equipment is required for full servicing of the air conditioning system.

Recovery, recycling and charging station Leak detector Thermometer +20° C to -60° C Safety goggles and gloves

Precautions when handling refrigerant lines

 **WARNING:** Wear eye and hand protection when disconnecting components containing refrigerant. Plug all exposed connections immediately.

- When disconnecting any hose or pipe connection the system must be discharged of all pressure. Proceed cautiously, regardless of gauge readings. Open connections slowly, keeping hands and face well clear, so that no injury occurs if there is liquid in the line. If pressure is noticed, allow it to bleed off slowly.
- Lines, flexible end connections and components must be capped immediately they are opened to prevent the entrance of moisture and dirt.
- Any dirt or grease on fittings must be wiped off with a clean alcohol dampened cloth. Do not use chlorinated solvents such as trichloroethylene. If dirt, grease or moisture cannot be removed from inside the hoses, they must be replaced with new hoses.
- All replacement components and flexible end connections must be sealed, and only opened immediately prior to making the connection.
- Ensure the components are at room temperature before uncapping, to prevent condensation of moisture from the air that enters.
- Components must not remain uncapped for longer than 15 minutes. In the event of delay, the caps must be fitted.
- Receiver/driers must never be left uncapped as they contain Silica Gel crystals which will absorb moisture from the atmosphere. A receiver/ drier left uncapped must not be used, fit a new unit.
- The compressor shaft must not be rotated until the system is entirely assembled and contains a charge of refrigerant.
- A new compressor contains an initial charge of refrigerant oil. The compressor also contains a holding charge of gas when received which should be retained by leaving the seals in place until the pipes are re-connected.
- The receiver/drier should be the last component connected to the system to ensure optimum dehydration and maximum moisture protection of the system.
- All precautions must be taken to prevent damage to fittings and connections. Slight damage could cause a leak with the high pressures used in the system.
- Always use two wrenches of the correct size, one on each fitting when releasing and tightening refrigeration unions.
- Joints and 'O' rings should be coated with refrigeration oil to aid correct seating. Fittings which are not lubricated with refrigerant oil are almost certain to leak.
- All lines must be free of kinks. The efficiency of the system is reduced by a single kink or restriction.
- Flexible hoses should not be bent to a radius less than 90mm radius.
- Flexible hoses should not be within 100mm of the exhaust manifold.
- Completed assemblies must be checked for refrigeration lines touching metal panels. Any direct contact of lines and panels transmits noise and must be eliminated.

## PERFORMANCE TEST

 **WARNING:** R134A is hazardous.  
**REFER to:** Health and Safety Precautions (100-00, Description and Operation).

Carry out this test with hood and doors or windows open, air conditioning switched on, temperature control set to cold and blower at maximum speed. Set the air supply control to supply fresh air.

1. Close low pressure valve on refrigerant station.
2. Close high pressure valve on refrigerant station.
3. Connect a Refrigerant Station to the high and low pressure servicing connections.
4. Insert dry bulb thermometer into cold air outlet and position dry and wet bulb thermometer close to outside air inlet. Do not spill water from the wet thermometer (psychrometer).
5. Start engine and run it at 1500 rev/min for 10 minutes with air conditioning switched on.
6. Read both pressure gauges and thermometers. Check readings against table below with humidity between 60% and 80%.
7. Switch off air conditioning, stop engine, disconnect test equipment.

Performance range

Intake temperature	Outlet temperature	Low pressure	High pressure
68°F	41 - 50°F	20 - 23 lbf/in <sup>2</sup>	116 - 190 lbf/in <sup>2</sup>
20°C	5 - 10°C	1.4 - 1.6 bar	8.0 - 13 bar
75°F	45 - 60°F	21 - 28 lbf/in <sup>2</sup>	130 - 200 lbf/in <sup>2</sup>
25°C	7 - 15°C	1.5 - 2.0 bar	9.0 - 14 bar
85°F	46 - 68°F	26 - 40 lbf/in <sup>2</sup>	190 - 230 lbf/in <sup>2</sup>
30°C	8 - 20°C	1.8 - 2.8 bar	13 - 16 bar
95°F	52 - 72°F		
35°C	11 - 22°C	2.5 - 3.5 bar	16 - 19 bar

Ambient temperature		Compound gauge readings		High pressure gauge readings	
°C	°F	bar	lbf/in <sup>2</sup>	bar	lbf/in <sup>2</sup>
16	60	1,3-1,4	15-20	6,9-10,3	100-150

27	80	1,4-1,7	20-25	9,7-13,1	140-190
38	100	1,7-2,1	25-30	12,4-15,5	180-225
43	110	2,1-2,4	30-35	14,8-17,2	215-250

# Climate Control System - General Information - Air Conditioning (A/C) System Recovery, Evacuation and Charging

## General Procedures

### WARNINGS:



The air conditioning system is charged with a high pressure, potentially toxic refrigerant. Repairs or servicing must only be carried out by an operator familiar with both the vehicle system and the charging and testing equipment. All operations must be carried out in a well-ventilated area away from open flame and heat sources. Always wear safety goggles and gloves when opening refrigerant connections.



Wear eye and hand safety protection. Open connections slowly in case liquid or pressure is present. Allow to bleed off slowly.



**CAUTION:** Overcharging air conditioning system will cause excessive head pressure.

1. Remove dust caps from high and low pressure connectors.
2. Connect high and low pressure hoses to appropriate connections.
3. Open valves on connectors.
4. Turn valves on refrigerant station to correct positions.
5. Turn Process switch to correct position.
6. Turn Main switch to 'ON'.
7. Allow refrigerant station to recover refrigerant from system.
8. Close valves on refrigerant station.
9. Turn Main switch to 'OFF'.
10. Close valves on connectors.
11. Disconnect high and low pressure hoses from connectors.
12. Fit dust caps to connectors.
13. Open tap at rear of station to drain refrigerant oil recovered from system.
14. Measure and record quantity of refrigerant oil recovered from system.
15. Close tap at rear of station.
16.  **WARNING:** Refrigerant must always be recycled before reuse, to ensure that the purity of the refrigerant is high enough for safe use in the air conditioning system. Recycling should always be carried out with equipment which is design certified by Underwriter Laboratory Inc. for compliance with SAE-J1991. Other equipment may not recycle refrigerant to the required level of purity. A R134a Refrigerant Recovery Recycling Recharging Station must not be used with any other type of refrigerant. Refrigerant R134a from domestic and commercial sources must not be used in motor vehicle air conditioning systems.  
  
Measure the quantity of oil discharged from the system. Add an equal amount of new refrigerant oil to compressor before evacuation sequence.

17. **CAUTIONS:**



When a major repair has been carried out, a leak test should be carried out using inert gas.



Whenever the refrigerant system is opened, the receiver/drier must be renewed immediately before evacuating and recharging the system.

Renew the receiver/drier.

18. Remove dust caps from high and low pressure connectors.
19. Connect high and low pressure hoses to appropriate connections.
20. Open valves on connectors.
21. Turn valves on refrigerant station to correct positions.
22. Turn Process switch to correct position.
23. Turn Main switch to 'ON'.
24. Allow refrigerant station to evacuate system.



**CAUTION:** The system must be Evacuated immediately before recharging commences. Delay between Evacuation and Recharging is not permitted.

25. If the vacuum reading is below 700 mm Hg, 28 in Hg after 15 minutes, suspect a leak in the system. Partially recharge the system and check for leaks using an electronic leak tester. Check suction lines first, then run the compressor for 5 minutes and then check the high pressure lines.

26. **WARNINGS:**



A R134a Refrigerant Recovery Recycling Recharging station must not be used with any other type of refrigerant.



R134a refrigerant from domestic and commercial sources must not be used in motor vehicle air conditioning systems.



**CAUTION:** When a major repair has been carried out, a leak test should be carried out using inert gas.

Close valves on refrigerant station.

27. Close valve on oil charger.
28. Disconnect yellow hose from refrigerant station.
29. Remove lid from oil charger.
30. Pour correct quantity of refrigerant oil into oil charger.
31. Fit lid to oil charger.
32. Connect yellow hose to refrigerant station.
33. Open valve on oil charger.
34. Move pointer on refrigerant gauge to mark position of refrigerant drop.
35. Slowly open correct valve on refrigerant station and allow vacuum to pull refrigerant into system.



36. Close valve on refrigerant station when correct amount of refrigerant has been drawn into air conditioning system.
37. If the full charge is not accepted by the system, start the engine and run it at 1,500 rev/min for a minimum of 2 minutes. Switch on the air conditioning system, open the vehicle windows, set the temperature control to cold and the blower switch to maximum.
38. Consult Refrigerant station instruction manual for correct procedure to complete the charge.
39. Turn Main switch to 'OFF'.
40. Close valves on connectors.
41. Disconnect high and low pressure hoses from connectors.
42. Fit dust caps to connectors.
43. Carry out performance test on air conditioning system.

# Climate Control System - General Information - Refrigerant System Tests

## General Procedures

1. Place the vehicle in a ventilated, shaded area free from excessive draught, with the doors and windows open.
2. Check that the surface of the condenser is not restricted with dirt, leaves, flies, etc. Do not neglect to check the surface between the condenser and the radiator. Clean as necessary.
3. Switch on the ignition and the air conditioner air flow control. Check that the blower is operating efficiently at low, medium and high speeds. Switch off the blower and the ignition.
4. Check that the evaporator drain tube is open and clear.
5. Check the tension of the compressor driving belt, and adjust if necessary.
6. Inspect all connections for the presence of refrigerant oil. If oil is evident, check for leaks, and repair as necessary.

NOTE: The compressor oil is soluble in Refrigerant R134a and is deposited when the refrigerant evaporates from a leak.

7. Start the engine.
8. Set the temperature controls to cold and switch the air conditioner blower control on and off several times, checking that the magnetic clutch on the compressor engages and releases each time.
9. With the temperature control at maximum cooling and the blower control at high speed, warm up the engine and fast idle at 1000 rev/min.
10. Repeat at 1800 rev/min.
11. Gradually increase the engine speed to the high range and check the sight glass at intervals.
12. Check for frosting on the service valves.
13. Check the high pressure hoses and connections by hand for varying temperature. Low temperature indicates a restriction or blockage at that point.
14. Switch off the air conditioning blower and stop the engine.
15. If the air conditioning equipment is still not satisfactory, carry out a pressure test as previously described in this section.

# Climate Control System - General Information - Electronic Leak Detection

## General Procedures



**CAUTION:** When a major repair has been carried out, a leak test should be carried out using an inert gas (see below).

1. Place the vehicle in a well ventilated area but free from draughts, as leakage from the system could be dissipated without detection.
2. Follow the instructions issued by the manufacturer of the particular leak detector being used.
3. Commence searching for leaks by passing the detector probe around all joints and components, refrigerant gas is heavier than air.
4. Insert the probe into an air outlet of the evaporator or into the evaporator drain tube. Switch the air conditioning blower on and off at intervals of ten seconds. Any leaking refrigerant will be gathered in by the blower and detected.
5. Insert the probe between the magnetic clutch and compressor to check the shaft seal for leaks.
6. Check all service valve connections, valve plate, head and base plate joints and back seal plate.
7. Check the condenser for leaks at the pipe unions.
8. If any leaks are found, the system must be discharged before rectification.
9. Rectify any leaks and recheck for leaks during evacuation prior to charging.
10. Leak test using inert gas
  1. Connect gas line to recharging station.
  2. Pressurise system to 3 bar (45 lbf/in<sup>2</sup>).
  3. Carry out leak test as above.

# Air Distribution and Filtering - Air Distribution and Filtering

Description and Operation

## COMPONENT LOCATION

NOTE: left-hand drive (LHD) vehicle shown, right-hand drive (RHD) similar.

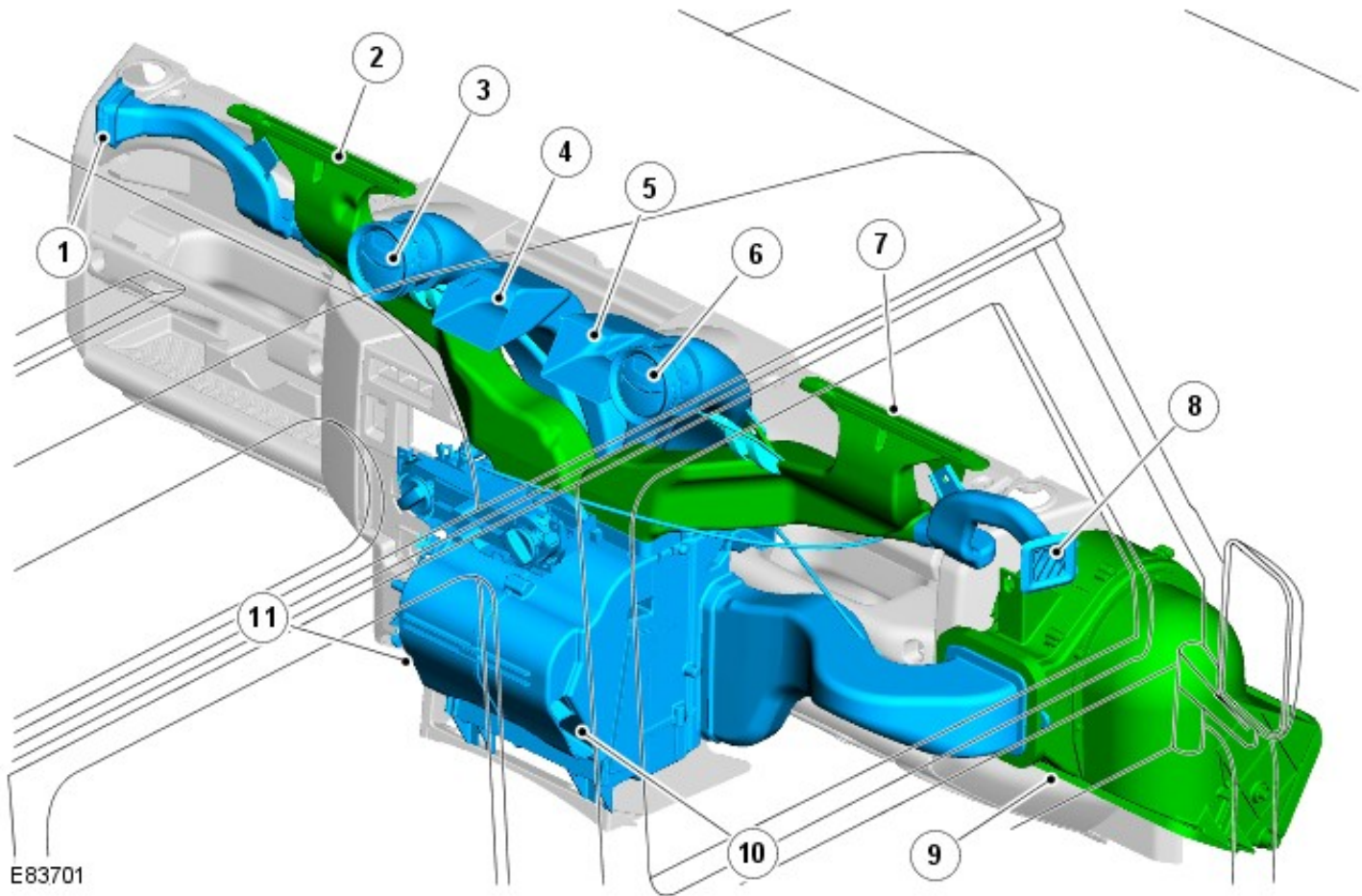

Item	Part Number	Description
1	-	left-hand (LH) side window vent
2	-	Windshield LH vent
3	-	LH face level register
4	-	LH face level vent
5	-	right-hand (RH) face level vent
6	-	RH face level register
7	-	Windshield RH vent
8	-	RH side window vent
9	-	Recirculated air inlet
10	-	RH footwell vent
11	-	LH footwell vent

## OVERVIEW

Air intake into the cabin is controlled using a 2 position sliding switch located on the center console. Either fresh or recirculated air can be selected. Selections are transmitted to the air intake and blower assembly using a Bowden cable. The air intake and blower assembly is located in the engine compartment.

Fresh air enters the system through the air inlet duct mounted in the passenger side front fender. Inlet air travels through the air intake and blower assembly to the heater assembly where it is distributed into the front of the cabin via a series of ducts, registers and vents.

NOTE: The vehicle is not fitted with a pollen filter.

When selected, recirculated air enters the system through an inlet located in the lower surface of the instrument panel, above the passenger foot well.

Air distribution into the cabin is selected using the RH rotary control mounted on the center console. A Bowden cable transmits selections to 2 air distribution doors using cams mounted on the heater assembly.

For additional information, refer to: Climate Control System (412-00, Description and Operation).

# Air Distribution and Filtering - Air Inlet Duct Removal and Installation

## Removal

NOTE: left-hand drive (LHD) vehicle shown, right-hand drive (RHD) similar.

1. Remove the passenger side fresh air intake grille.



2. Remove the 2 air inlet duct upper securing screws.

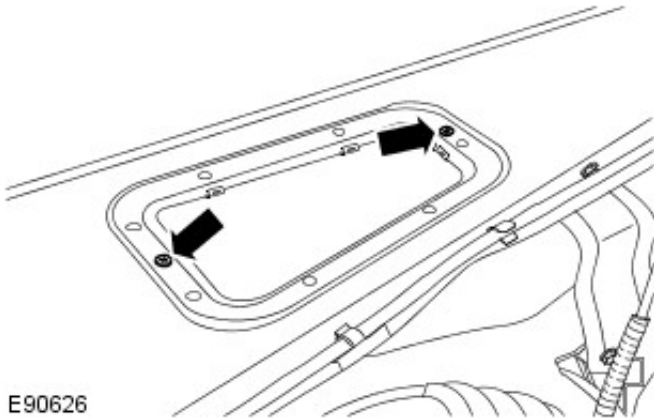

3. Remove the 2 air inlet duct retaining bracket securing bolts and retaining bracket.

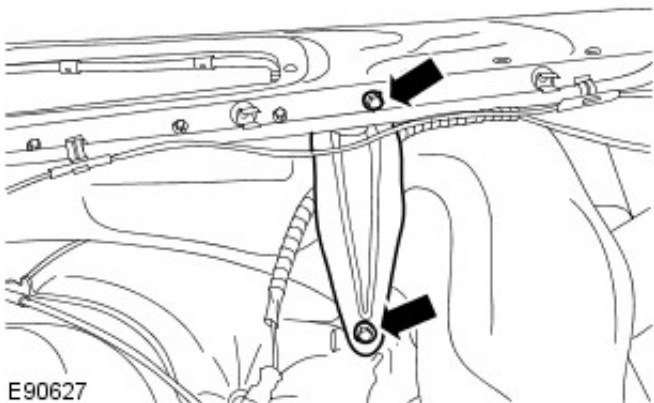

4. NOTE: Left-hand drive (LHD) vehicles only.

Disconnect the mass air flow (MAF) sensor electrical connector.

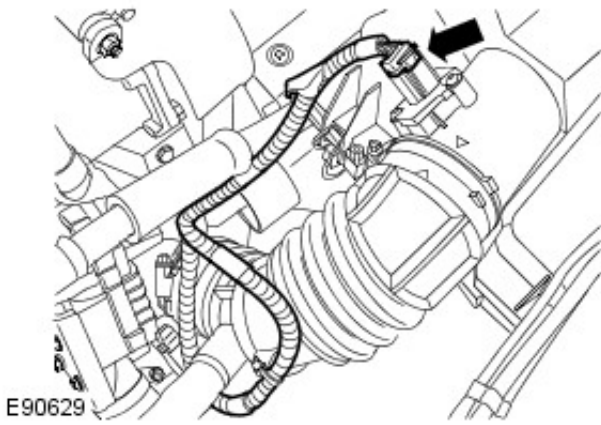

5. NOTE: Left-hand drive (LHD) vehicles only.  
Release the air cleaner outlet pipe clip.

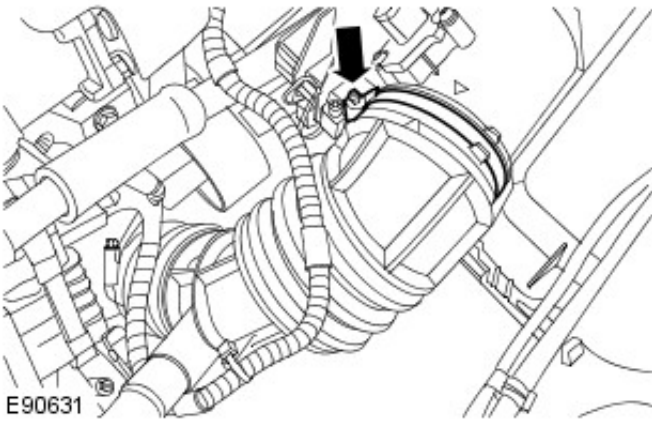

6. NOTE: Left-hand drive (LHD) vehicles only.  
Release the air cleaner outlet pipe

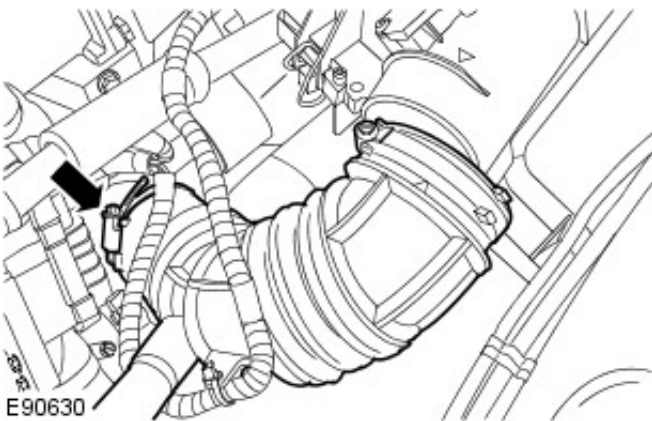

7. Remove the air intake duct

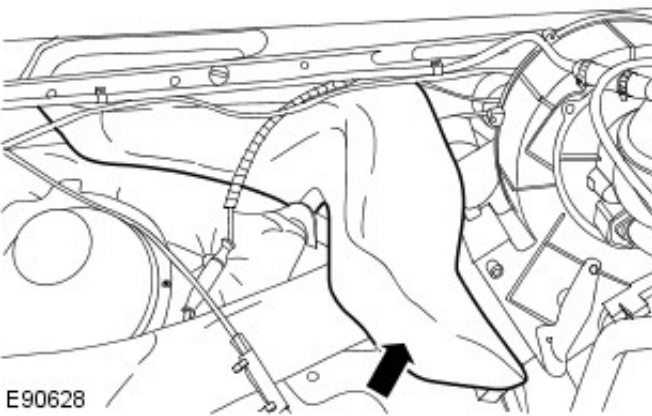

## Installation

NOTE: To prevent water ingress, make sure the air inlet duct is correctly aligned with the blower motor seal.

1. To install, reverse the removal procedure.

