

## Section 4

# Hybrid Vehicle Control System

---

**Overview** The Hybrid Vehicle Control System monitors and adjusts all aspects of the hybrid powertrain.

- It regulates the engine, MG1 and MG2 to meet the driving demands signaled by shift position, accelerator pedal position and vehicle speed.
- It controls the operation of the hybrid transaxle.
- It oversees the operation of the inverter and converter as they balance the power requirements of the vehicle's many 12-volt components and the high voltage components of the hybrid system powertrain.

Before we look at the components that make up the Hybrid Vehicle Control System, let's review the special safety precautions that must be taken to ensure safe servicing of the HV system.

### Safety Procedures

Repairs performed incorrectly on the Hybrid Control System could cause electrical shock, leakage or explosion. Be sure to perform the following procedures:

- Remove the key from the ignition. If the vehicle is equipped with a smart key, turn the smart key system OFF.
- Disconnect the negative (-) terminal cable from the auxiliary battery.
- Wear insulated gloves.
- Remove the service plug and **do not make any repairs for five minutes.**

If the key cannot be removed from the key slot in the case of an accident, be sure to perform the following procedures:

- Disconnect the auxiliary battery
- Remove the HEV fuse (20A yellow fuse in the engine compartment junction block). When in doubt, pull all four fuses in the fuse block.

#### NOTE

In order for your insulated gloves to provide proper protection, the insulating surface must be intact.

To check the integrity of the glove's surface, blow air into the glove and fold the base of the glove over to seal the air inside. Then slowly roll the base of the glove towards the fingers.

- If the glove holds pressure, its insulating properties are intact.
- If there is an air leak, high voltage electricity can find its way back through that same hole and into your body! Discard the glove and start over until you have a pair of intact gloves that can fully protect you from the vehicle's high voltage circuits.

**WARNING**

Due to circuit resistance, it takes at least five minutes before the high voltage is discharged from the inverter circuit.

Even after five minutes have passed the following safety precautions should be observed:

- Before touching a high voltage cable or any other cable that you cannot identify, use the tester to confirm that the voltage in the cable is 12V or less.
- After removing the service plug cover the plug connector using rubber or vinyl tape.
- After removing a high voltage cable be sure to cover the terminal using rubber or vinyl tape.
- Use insulated tools when available.
- Do not leave tools or parts (bolts, nuts, etc.) inside the cabin.
- Do not wear metallic objects. (A metallic object may cause a shortcircuit.)

**Submerged Vehicle Safety**

To safely handle a Prius that is fully or partially submerged in water, disable the high voltage electrical system and SRS airbags. Remove the vehicle from the water. Drain the water from vehicle if possible. Then follow the extrication and vehicle disable procedures below:

- Immobilize vehicle.
- Chock wheels and set parking brake.
- Remove the key from key slot.
- If equipped with a smart key, use the smart cancel switch underneath the steering column to disable the system.
- Keep the electronic key at least 16 feet (5 meters) away from the vehicle.
- Disconnect the 12V auxiliary battery.
- Remove the HEV fuse in the engine compartment. When in doubt, pull all four fuses in the fuse block.

**WARNING**

After disabling the vehicle, power is maintained for 90 seconds in the SRS system and five minutes in the high voltage electrical system. If either of the disable steps above cannot be performed, proceed with caution as there is no assurance that the high voltage electrical system, SRS, or fuel pump are disabled. Never cut orange high voltage power cables or open high voltage components.

**Hybrid Transaxle** The Hybrid Transaxle contains:

- Motor Generator 1 (MG1) that generates electrical power.
- Motor Generator 2 (MG2) that drives the vehicle.
- A planetary gear unit that provides continuously variable gear ratios and serves as a power splitting device.
- A reduction unit consisting of a silent chain, counter gears and final gears.
- A standard 2-pinion differential.

**P111 Transaxle** The '01-'03 Prius uses the P111 hybrid transaxle.  
**('01-'03) Prius**

***Transaxle Cutaway***

Figure 4.1

T072f401p

**P112 Transaxle** The '04 and later Prius uses the P112 transaxle. The P112 is based on the P111, but offers a higher RPM range, V-shaped permanent magnets in the rotor of MG2 and a newly designed over-modulation control system.  
**('04 & later Prius)**

**Transaxle Damper** A coil spring damper with low torsion characteristics transmits the drive force from the engine. Also, a torque fluctuation absorbing mechanism that uses a dry-type single-plate friction material is used.

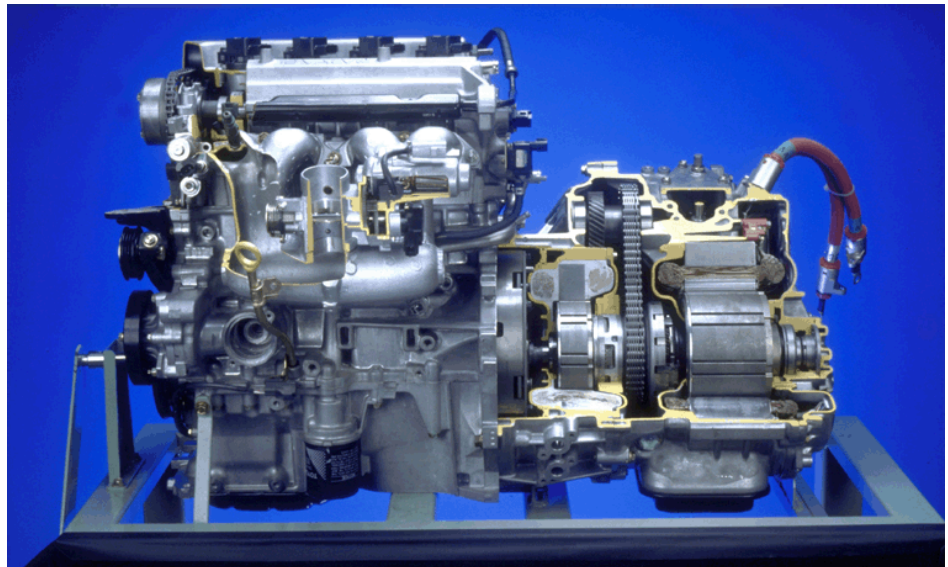
On the '04 and later Prius the spring rate characteristics of the coil spring have been reduced further to improve its vibration absorption performance. Also, the shape of the flywheel has been optimized for weight reduction.

### Hybrid Transaxle Specifications

		'03 Model	'04 Model
Transaxle Type		P111	P112
Planetary Gear	The No. of Ring Gear Teeth	78	←
	The No. of Pinion Gear Teeth	23	←
	The No. of Sun Gear Teeth	30	←
Differential Gear Ratio		4.113	3.905
Chain	Number of Links	72	74
	Drive Sprocket	36	39
	Driven Sprocket	35	36
Counter Gear	Drive Gear	30	←
	Driven Gear	44	←
Final Gear	Drive Gear	26	←
	Driven Gear	75	←
Fluid Capacity	Liters (US qts, Imp qts)	3.8 (4.0, 3.3)	4.6 (4.9, 4.0)
Fluid Type		ATF WS or equivalent	ATF Type T-IV or equivalent

**MG1 & MG2 (Motor Generator 1 & Motor Generator 2)** Both MG1 and MG2 function as both highly efficient alternating current synchronous generators and electric motors. MG1 and MG2 serve as the source for supplemental motive force that provides power assistance to the engine as needed.

**MG1 Description** MG1 recharges the HV battery and supplies electrical power to drive MG2. In addition, by regulating the amount of electrical power generated (thus varying the generator's rpm), MG1 effectively controls the continuously variable transmission function of the transaxle. MG1 also serves as the engine starter.

**MG2 Description** MG2 serves as the supplemental motive force that provides power assist to the engine output. It helps achieve excellent dynamic performance that includes smooth start-off and acceleration. During regenerative braking, MG2 converts kinetic energy into electrical energy which is then stored by the HV battery.

**NOTE**

Towing a damaged Prius with its front wheels on the ground may cause the motor to generate electricity. The electrical insulation could leak and cause a fire. Always tow the vehicle with the front wheels off of the ground or on a flat bed.

**Power Splitting Device**

The planetary gear unit is used as a power splitting device. The sun gear is connected to MG1, the ring gear is connected to MG2, and the planetary carrier is connected to the engine output shaft. The motive force is transmitted from the chain drive sprocket drive to the reduction unit via a silent chain.

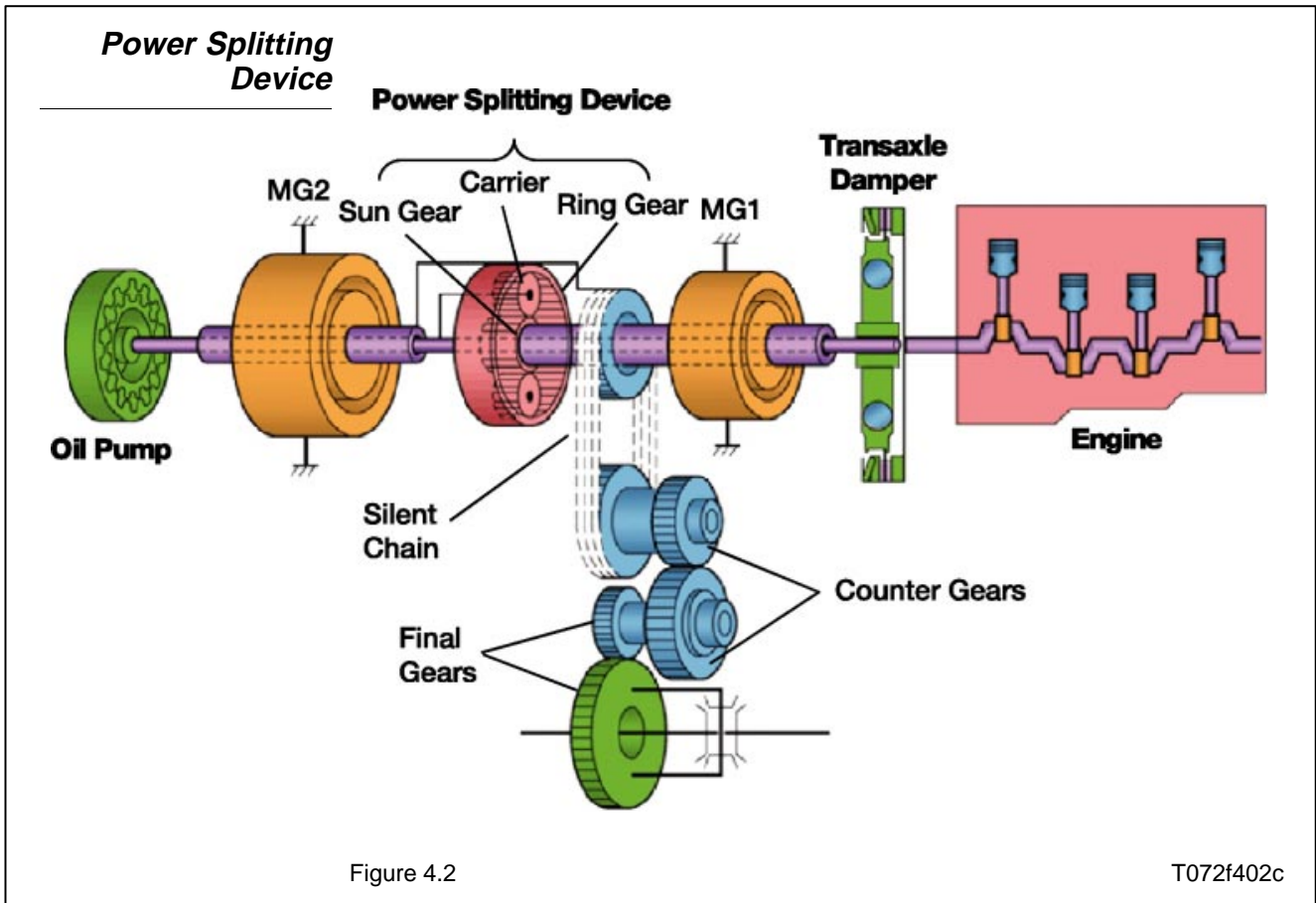

Figure 4.2

T072f402c

**Planetary Gear Connection**

Item	Connection
Sun Gear	MG1
Ring Gear	MG2
Carrier	Engine Output Shaft

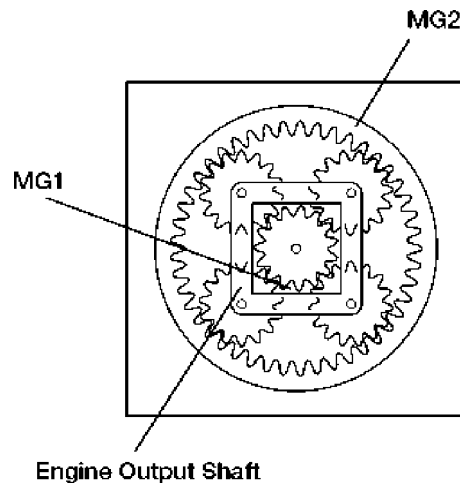

Figure 4.3

T072f403

**Permanent Magnet Motor**

When three-phase alternating current is passed through the three-phase windings of the stator coil, a rotating magnetic field is created in the electric motor. By controlling this rotating magnetic field according to the rotor's rotational position and speed, the permanent magnets in the rotor become attracted by the rotating magnetic field, thus generating torque. The generated torque is for all practical purposes proportionate to the amount of current and the rotational speed is controlled by the frequency of the alternating current.

A high level of torque can be generated efficiently at all road speeds by properly controlling the rotating magnetic field and the angles of the rotor magnets.

On the '04 & later Prius the built-in permanent magnets have been changed to a V-shaped structure to improve both power output and torque. This improvement provides about 50% more power than previous models.

**Speed Sensor (Resolver)**

This reliable and compact sensor precisely detects the magnetic pole position, which is indispensable for ensuring the efficient control of MG1 and MG2.

The sensor's stator contains three coils. Since the rotor is oval, the gap between the stator and the rotor varies with the rotation of the rotor.

In addition, the HV ECU uses this sensor as an rpm sensor calculating the amount of positional variance within a predetermined time interval.

**DTC P0A4B  
Generator  
Position Sensor  
Circuit**

DTC P0A4B will set when the HV ECU detects output signals that are out of normal range or specification concluding that there is a malfunction of the generator resolver. The following Information Codes can help isolate the problem:

- (’04 & later Prius)
- 253 - Interphase short in resolver circuit
  - 513 - Resolver output is out of range
  - 255 - Open or short in resolver circuit

**DTC P1525  
Resolver  
Malfunction**

DTC P1525 will set when vehicle speed signals are not input from the resolver for 16 seconds or more while running at a speed of 20km/h or more. The trouble areas could include the:

- (’01 & ’03 Prius)
- ECM
  - HV ECU
  - Wire Harness

**Speed Sensor (Re-  
solver) Operation**

Output coils B and C are electrically staggered 90 degrees. Because the rotor is oval, the distance of the gap between the stator and the rotor varies with the rotation of the rotor. By passing an alternating current through coil A, output that corresponds to the sensor rotor's position is generated by coils B and C. The absolute position can then be detected from the difference between these outputs.

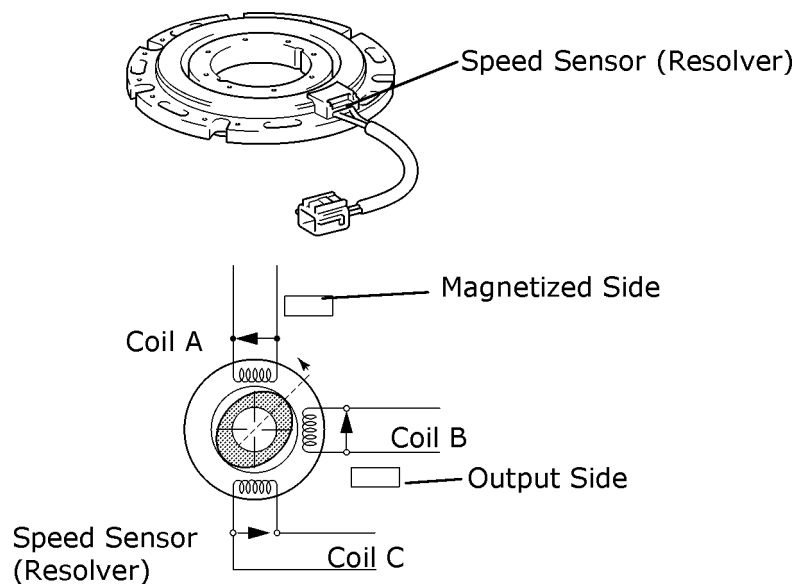

Figure 4.4

182TH09

**Shift Assembly  
(’04 & later Prius)**

The shift position sensors consist of a select sensor that detects the lateral movement of the selector lever and a shift sensor that detects the longitudinal movement. A combination of these signals is used to detect the shift position.

**Shift Assembly**

(’04 & later Prius)

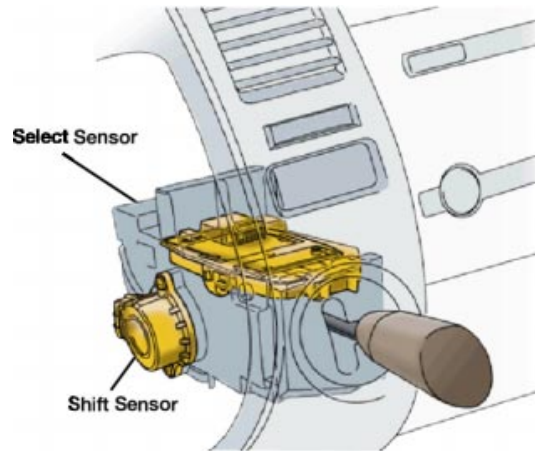

Figure 4.5

T072f405c

**Shift Control  
Actuator  
(’04 & later Prius)**

The motor in the actuator rotates to move the parking lock rod, which slides into the parking lock pawl, causing it to engage with the parking gear. This actuator detects its own position when a battery is reinstalled, so it does not require initialization.

**Shift Control  
Actuator**

(’04 & later Prius)

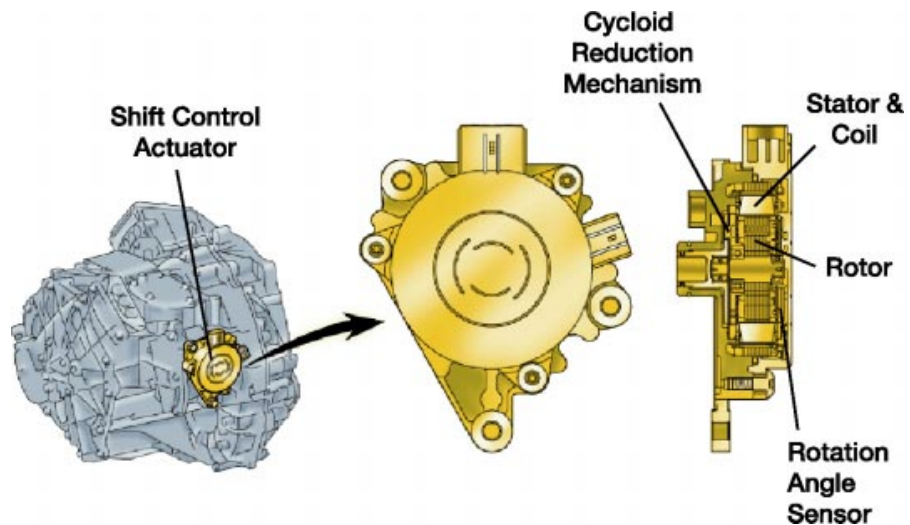

Figure 4.6

T072f406c



### Cycloid Reduction Mechanism ('04 & later Prius)

The Shift Control Actuator includes a cycloid gear reduction mechanism that increases the actuator's torque, ensuring that the parking lock will release when the vehicle is parked on a slope.

This mechanism consists of an eccentric plate mounted on the motor's output shaft, a 61-tooth fixed gear that is secured to the motor housing and a 60-tooth driven gear. As the output shaft rotates, the eccentric plate presses the driven gear against the fixed gear. The driven gear, which has one tooth less than the fixed gear, rotates one tooth for every complete rotation of the eccentric plate. The result is a gear reduction ratio of 61:1, along with an equivalent increase in torque.

#### Cycloid Reduction Mechanism

1. Eccentric shaft rotates with motor shaft, pressing driven gear against fixed gear.
2. Driven gear rotates one tooth for every full rotation of the motor shaft.
3. Reduction Ratio: 61:1.

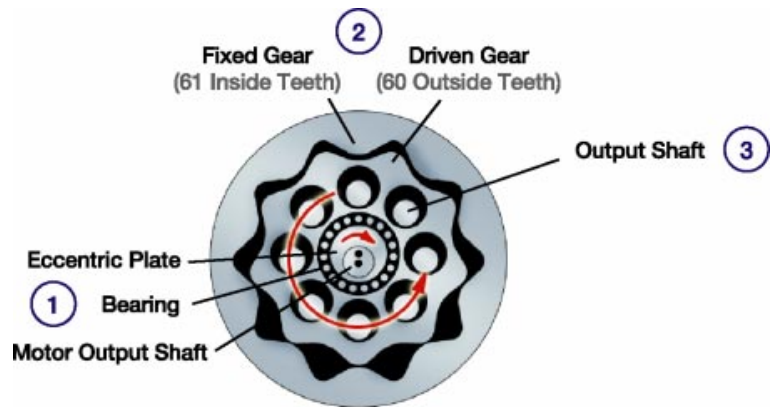

Figure 4.7

255CH13

#### SERVICE TIP

If there is a malfunction in the shift control actuator the vehicle will not go into park. The Master Warning Light will illuminate, the shift position indicators on the dash will flash and the Park light button will flash. In this case, the vehicle cannot be turned OFF.

To get the vehicle to shut off, stop the vehicle and apply the parking brake. The vehicle can be turned OFF but cannot be turned back ON.

#### SERVICE TIP

A diagnostic tester cannot turn off the shift control system so remove the 30 amp fuse located on the left side of the fuse box on the driver's side.

## Opened Inverter Assembly

('04 & later Prius)



Figure 4.8

T072f408p

**Inverter** The Inverter converts the high voltage direct current of the HV battery into three-phase alternating current of MG1 and MG2. The activation of the power transistors is controlled by the HV ECU. In addition, the inverter transmits information that is needed to control current such as the output amperage or voltage, to the HV ECU.

The inverter, MG1, and MG2 are cooled by a dedicated radiator and coolant system that is separate from the engine coolant system. The HV ECU controls the electric water pump for this system. In the '04 & later Prius, the radiator has been simplified and the space it occupies has been optimized.

**Boost Converter ('04 & later Prius)** The boost converter boosts the nominal voltage of DC 201.6V that is output by the HV battery to the maximum voltage of DC 500V. The converter consists of the boost Integrated Power Module (IPM) with a built-in Insulated Gate Bipolar Transistor (IGBT) which performs the switching control and the reactor which stores energy. By using these components the converter boosts the voltage.

When MG1 or MG2 acts as a generator the inverter converts the alternating current (range of 201.6V to 500V) generated by either of them into direct current. The boost converter then drops it to DC 201.6V to charge the HV battery.

- Converter** Power for auxiliary equipment in the vehicle such as lights, the audio system, the A/C cooling fan, and ECUs is based on a DC 12V system.
- On the '01-'03 Prius, the THS generator voltage is DC 273.6V. The converter is used to transform the voltage from DC 273.6V to DC 12V in order to recharge the auxiliary battery.
- On the '04 Prius and later the THS-II generator voltage outputs at nominal voltage of DC 201.6V. The converter is used to transform the voltage from DC 201.6V to DC 12V in order to recharge the auxiliary battery.
- A/C Inverter ('04 & later Prius)** An A/C inverter, which supplies power for driving the electric inverter compressor of the A/C system, has been included in the inverter assembly. This inverter converts the HV battery's nominal voltage of DC 201.6V into AC 201.6V and supplies power to operate the compressor of the A/C system.
- HV ECU** The HV ECU controls the motor and engine based on torque demand and the HV battery SOC. Factors that determine motor and engine control are:
- Shift position
  - Accelerator pedal position
  - Vehicle speed
- DTC P3120 HV Transaxle Malfunction ('04 & later Prius)** The HV ECU checks the energy balance and detects an abnormality if the magnetism in the motor or generator greatly decreases.
- There are many Information Codes associated with this DTC. Refer to the DI section of the Repair Manual.
- DTC P3125 Converter & Inverter Assembly Malfunction** If the vehicle is being driven with a DC-to-DC converter malfunction the voltage of the auxiliary battery will drop and it will be impossible to continue driving. Therefore, the HV ECU checks the operation of the DC-to-DC converter and provides a warning to the driver if a malfunction is detected. DTC P3125 will be stored.

**NOTE**

A vehicle which has set both P3120 and P3125 may be difficult to diagnose. The reason both codes may set is because two independent current sensors are evaluating inverter and motor-generator performance. If a tire slips or a motor-generator mechanically binds or fails current flow values will be high. The inverter current sensor may detect the high current first and assume that the high current flow is caused by the inverter instead of the motor-generator.

**Diagnostic Procedures:**

- In most transaxle cases the engine will not start or makes a strange whining sound when cranking. If MG1 operates, swap the HV ECU. If the DTC resets, replace the inverter.
- If MG1 does not crank the engine, replace the inverter first.

**DTC P3000  
HV Battery  
Malfunction**

The HV ECU warns the driver and performs the fail-safe control when an abnormal signal is received from the battery ECU.

If Information Codes 123 or 125 are output, check and repair the applicable DTC. After repairs, record the DTC of the HV ECU, Freeze Frame data, and Operation History. Then clear the DTC and check one more time after starting the system again, (READY light ON).

If Information Code 388 is output, check for other Information Codes. Check and repair applicable codes. After that, confirm that there is sufficient gasoline to crank the engine.

If Information Code 389 is output, check for other Information Codes. Check and repair applicable codes. After that, replace the main battery and crank the engine.

**DTC P3009  
Insulation Leak  
Detected**

DTC P3009 sets when there is a leak in the high-voltage system insulation, which may seriously harm the human body. (Insulation resistance of the power cable is 100 k ohms or less.) If no defect is identified at inspection, entry of foreign matter or water into the battery assembly or converter and inverter assembly may be the possible cause. Use a Megger Tester to measure the insulation resistance between the power cable and body ground.

**Diagnostic Procedure:**

If a Megger Tester is not available, try these diagnostic procedures to help isolate the problem.

- With the key ON, and Ready light OFF, clear the DTC. Cycle the key and check for DTCs again. If the DTC appears again unplug the HV battery cable from the battery. If the DTC still resets the problem is in the HV Battery ECU or related cables, connectors,

etc. If the DTC does not set again the problem is in the front half of the vehicle including cables, transaxle, inverter, etc.

- To isolate front components, reconnect HV cables and start unplugging the farthest component (such as MG1 and MG2).

### **DTC P3009 Information Codes**

DTC P3009 can alert you to a short circuit in several different areas of the high-voltage system. The information code retrieved with the DTC helps you pinpoint the exact area of the short circuit. The diagram below shows the specific circuits associated with each of the following information codes:

- 526 - Vehicle Insulation Resistance Reduction
- 611 - A/C Area
- 612 - HV Battery Area
- 613 - Transaxle Area
- 614 - High Voltage DC Area

### **CAUTION**

Before inspecting the high-voltage system take safety precautions to prevent electrical shock such as wearing insulated gloves and removing the service plug. After removing the service plug put it in your pocket to prevent other technicians from reconnecting it while you are servicing the high-voltage system.

After disconnecting the service plug wait at least five minutes before touching any of the high-voltage connectors or terminals because it takes five minutes to discharge the high-voltage condenser inside the inverter.

## High-Voltage Circuit

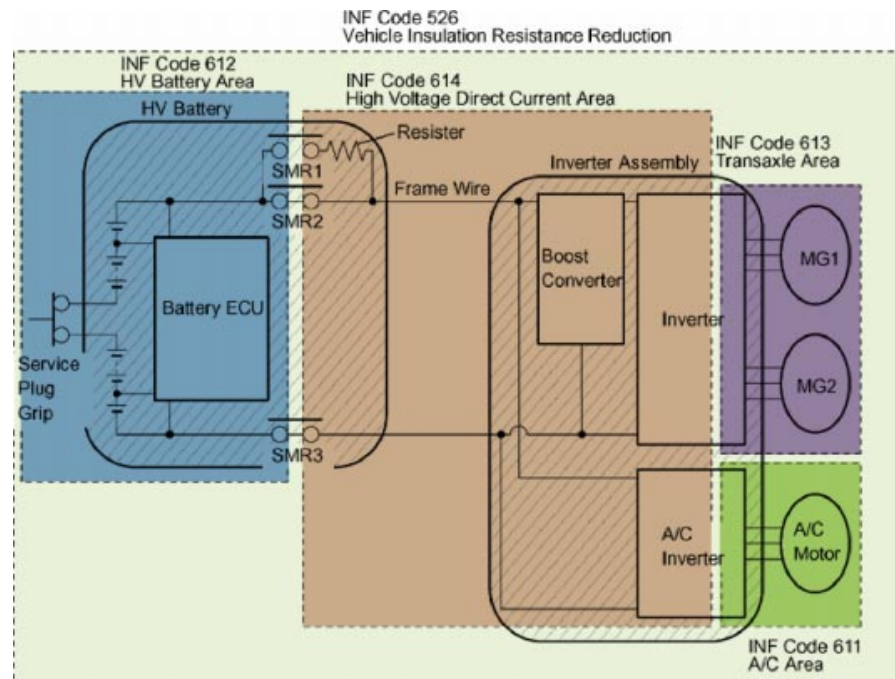

Figure 4.9

T072f409c

### DTC P3101 Engine System Malfunction (’01-’03 Prius)

The HV ECU performs the fail-safe control when the ECM detects an error, which will affect the THS control. Information Codes 204, 205, and 238 may set with this DTC. Information Code 204 detects an abnormal signal from the ECM (abnormal engine output). Information Code 205 detects an abnormal signal from the ECM (engine unable to start). Information Code 238 detects when the engine does not start when cranked. If this code is output, investigate what has increased revolution resistance in the transaxle or engine. Check the engine and transaxle lubrication systems, check the engine and transaxle coolant and check for any mechanical breakdowns in the engine and transaxle.

This DTC is likely to occur together with DTC P3190/P3191.

### DTC P3115 System Main Relay Malfunction

The HV ECU checks that the system main relay (No. 1, No. 2, No. 3) is operating normally and detects a malfunction. Information Codes 224-229 may be present. (Refer to the Repair Manual for each description.)

Confirm that there is no open circuit in the wire harness. If battery voltage is always applied to the HV ECU Cont1, Cont2 and Cont3 terminals with ignition ON (READY light OFF), the system main relay has a +B short.

If the vehicle exhibits a Master, Hybrid and MIL Warning Light, the condition can occur under the following circumstances:

- While decelerating with a slight accelerator pedal opening and with many electrical accessories in use, DTC P3115 will set in the HV Battery ECU and P3000 in the HV ECU.
- After turning the IG key to Start for the first trip after a cold soak in ambient temperatures below 32°F, Diagnostic Trouble Code P3115 will set in the HV ECU.

**HINT**

DTC P3115 may show up in the HV ECU section or the HV battery section of the Diagnostic Tester. Test SMR values to help locate the problem.

**Using  
Information  
Codes**

Information Codes are a three-digit sub-set of codes that provide data pertaining to HV ECU DTCs. They provide additional information and freeze frame data to help diagnose the vehicle's condition. These codes can be found using the Diagnostic Tester in the **HV ECU** screen. For a detailed description of each Information Code, refer to the DI section of the Repair Manual. Refer to the following screen flow to access Information Codes on the Diagnostic Tester.

### Accessing Information Codes

Follow the screen flow to access the Information Codes.

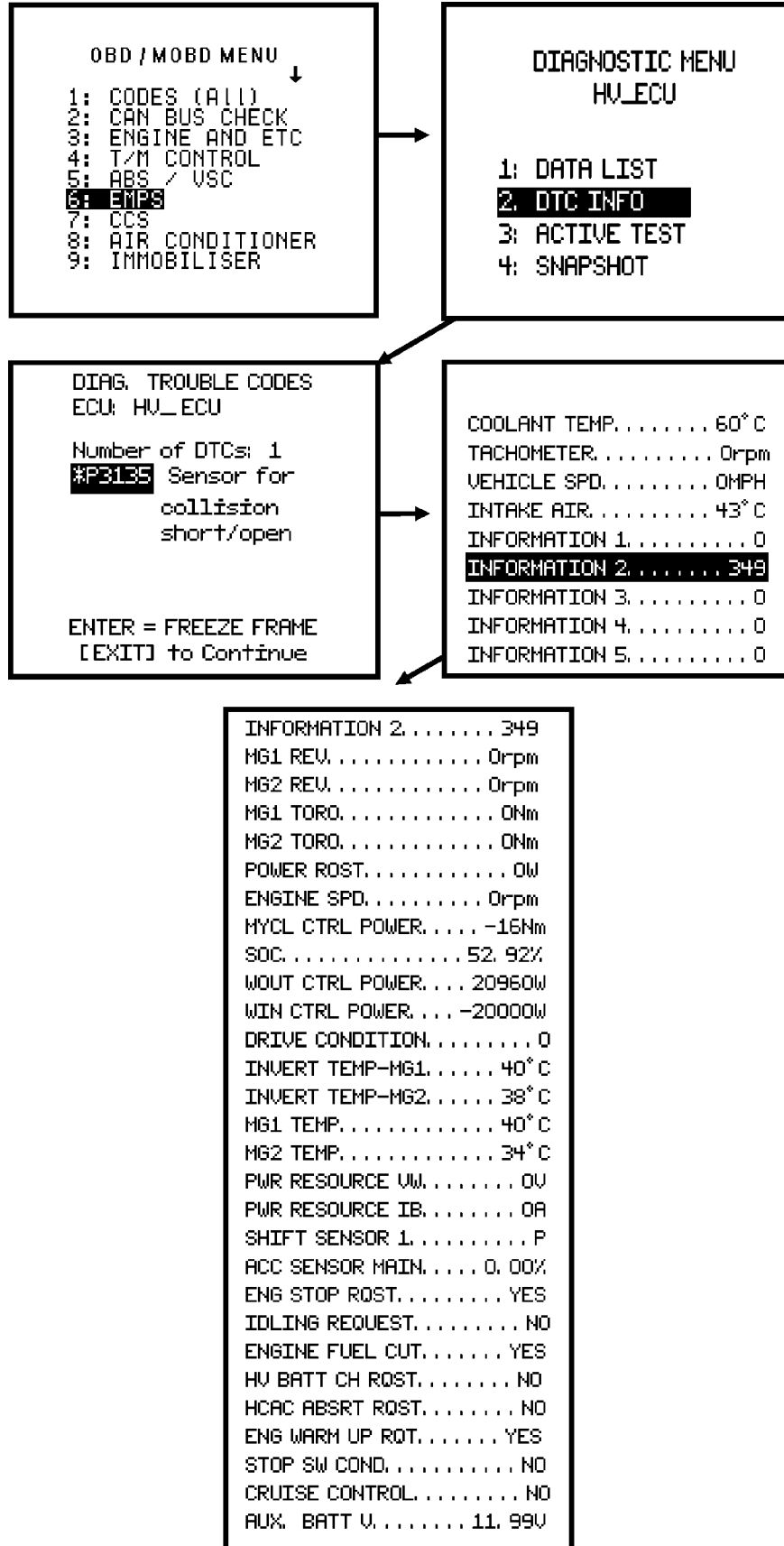

Figure 4.10

T072f410



## Using Operation History Data

Sometimes symptoms caused by the customer's driving habits may be mistaken for problems in the Prius. Operation History Data can be used for explaining that these symptoms may not indicate problems. It also can be used to view the driving patterns of the customer so that the concern can be diagnosed and fixed.

To view Operation History Data using the Diagnostic Tester:

- Connect the Diagnostic Tester to the DLC3.
- Turn the power switch ON (IG).
- Enter the following menus:
- DIAGNOSIS / ENHANCED OBD II / HV ECU / DATA LIST.
- Select the menu to view the number of special operations or controls that have been affected.

### HINT

- LATEST OPER: Among the past occurrences, the number of special operations or controls that have been effected during the most recent 1 trip detection.
- LATEST TRIP: The number of trips after the occurrence of LATEST OPER.
- BEF LATST OPER: The number of occurrences 1 previously from the LATEST OPER.
- BEF LATST TRIP: The number of trips after the occurrence of BEF LATST OPER.

### Operation History Data

Hand-held Tester Display	Count Condition
SHIFT BEF READY	Selector lever moved with READY lamp blinking
N RANGE CTRL 1	-
N RANGE CTRL 2	N position control effected due to frequent shifting operation
STEP ACCEL IN N	Accelerator pedal depressed in N position
AUX. BATT LOW	Auxiliary battery voltage below 9.5 V
HV INTERMITTENT	Instantaneous open at IGSW terminal of HV control ECU
MG2 (NO1) TEMP HIGH	Motor temperature climbed above 174°C (345°F)
MG2 (NO2) TEMP HIGH	Transaxle fluid temperature climbed above 162°C (324°F)
MG2 INV TEMP HIGH	Motor inverter temperature climbed above 111°C (232°F)
MG1 INV TEMP HIGH	Generator inverter temperature climbed above 111°C (232°F)
MAIN BATT LOW	Battery state of charge dropped below 30%
RESIST OVR HEAT	Limit resistor forecast temperature climbed above 120°C (248°F)
COOLANT HEAT	Inverter coolant forecast temperature climbed above 65°C (149°F)
CONVERTER HEAT	Boost converter temperature climbed above 111°C (232°F)
SHIFT P IN RUN	Shifted to P while driving
BKWRD DIR SHIFT	Shifted to R while moving forward or to D or B while moving in reverse
PREVENT STAYING	Engine speed resonance frequency band

### Accessing Operation History Data

Follow the screen flow to access Operation History. From the Select Data screen, select the type of information you want to review.

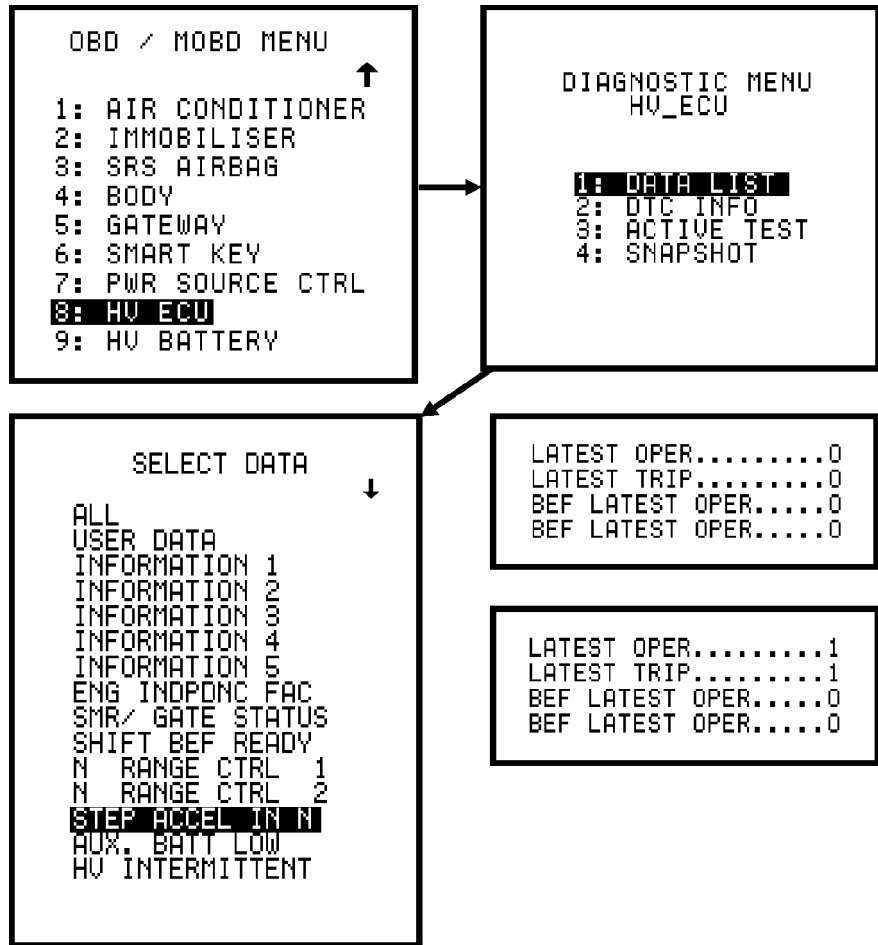

Figure 4.11

T072f411

**NOTE**

For more information regarding Operation History data, refer to the Appendix located in the back of this book.

**HV ECU Active Tests**

The following are useful HV ECU active tests which can be accessed when using the Diagnostic Tester:

**Inspection Mode 1**

- Used to check its operation while the engine is still running. Also used to disable traction control while performing a speedometer test.
- This mode runs the engine continuously in the P position. It also cancels the traction control that is affected when the rotational difference between the front and rear wheels is excessive other than the P position.
- The test condition is power switch ON (IG), HV system normal, not in inspection mode, and other active tests not being executed.

**Inspection Mode 2**

- Used to disable traction control while performing a speedometer test or the like.
- This mode cancels the traction control that is affected when the rotational difference between the front and rear wheels is excessive other than the P position.
- The test condition is power switch ON (IG), HV system normal, not in inspection mode, and other active tests not being executed.

**Inverter Stop**

- Used to determine if there is an internal leak in the inverter or the HV control ECU.
- This mode keeps the inverter power transistor actuation ON.
- The test condition is power switch ON (IG), P position, HV system normal, inverter actuation not being disabled, shutting down inverter, and other active tests not being executed.

**Cranking Request**

- Used to crank the engine continuously in order to measure the compression.
- This mode allows the engine to continuously crank by activating the generator continuously.
- The test condition is power switch ON (IG), HV system normal, not in cranking mode, and other active tests not being executed.

**Prius General  
Diagnostic Flow**

When diagnosing the Prius, follow the diagnostic procedures below. Always put the DTCs in a logical hierarchy. For example, an engine control problem that sets a Check Engine light may eventually cause HV ECU codes.

1. What warning lights are ON? (Critical Information!)
2. What is the customer's complaint?
3. What is the condition of the vehicle?
4. Do steps 1-3 agree with each other?
5. Always use "ALL CODES" and print DTCs from each ECU.
6. For multiple DTCs, check the occurrence order.
7. What power source was affected first?
8. How were the other power sources or systems affected?
9. Isolate the system affected first.

**NOTE**

ALWAYS print Freeze Frame Data! This is important, especially when calling TAS.



**Notes**